



Manage Risk Better with Bulk Fertilizer

The cost of crop nutrition is a major piece of your profitability puzzle. One way to take back more control and manage your price risk is to add bulk fertilizer storage capacity to your farm.

ADM is working closely with equipment manufacturer Meridian, a well-known and respected brand. The ADM On-farm Fertilizer Storage Program provides you with one-stop, cost-effective bin and conveyor solutions.

ADM is providing special pricing for program participants. ADM is not a party to the purchase of Meridian storage equipment from Meridian by program participant.

ADM Fertilizer

On-farm Fertilizer Storage Program:
Store in Bulk, Save Money

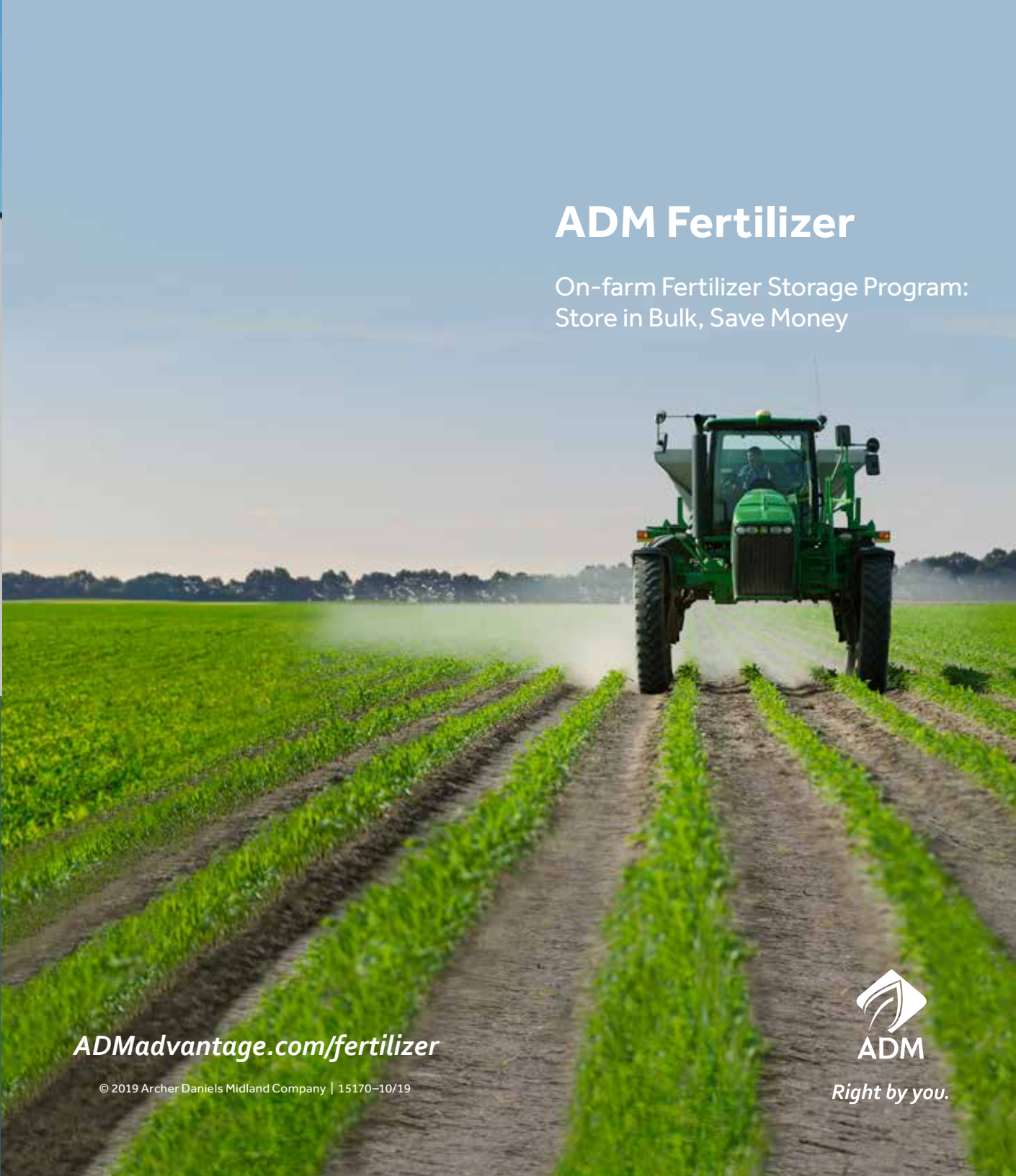

ADMadvantage.com/fertilizer

© 2019 Archer Daniels Midland Company | 15170-10/19



Right by you.

“Having Meridian Upright Storage Bins has allowed me more control than ever when it comes to having fertilizer on my farm when I need it and being able to take delivery of my fertilizer when I want it.

Also, it allows me the flexibility to spread when I need to and not wait for my local retailer to make it out here when it’s convenient for him or when they have time.”

Loncorich Family Farms

ADM On-farm Fertilizer Storage Program

Competitive Transparent Pricing

ADM provides insight into fertilizer pricing and competitive supply options. We are committed to price transparency on the crop nutrition you need, up to 18 months forward.

Efficient Logistics

Through ADM’s extensive transportation and warehousing network, we deliver the right product at the right time. Having on-farm storage bins means better control over key parts of your operation.

Quality Supply

ADM is committed to high-quality, diverse fertilizer products that are tailored to your needs, so you can optimize your inputs investment.

Convenient Financing

Flexible financing options, up to 0%, are available for qualified applicants. Subject to APR through lender partner.

Peace of Mind

Meridian’s premium storage solutions are covered by an extensive manufacturer’s warranty:

- 10-year structural warranty on bins
- 5-year powder coating warranty on bins
- 1-year structural and paint warranty on conveyors

Meridian Multi-purpose Smoothwall Bins Feature:

Model 1420 or 1620

- Capacity of 104 or 150 tons
- Premium powder coat finish for years of corrosion and abrasion resistance
- Cone-shaped design ensures 100% cleanout for zero waste
- Custom-designed venting helps to prevent moisture inside the bin
- Premium, stainless steel, rack-n-pinion slide gate with crank
- Complete sidewall and roof ladder
- 24" clearance under the slide gate
- 15' 6" diameter/1520 multi-purpose bins are applicable for states that cannot ship 1620 bins

Meridian Conveyors Feature:

- Reliable and long-lasting design
- High-capacity belt with unique crescent shaped cleats provide superior product movement
 - The rM series belt conveyor features gas or diesel motor or PTO drive
- Available with two drive systems: Single End or Dual End
 - Provides flexibility based on conveyor length and capacity requirements
- Easy-to-remove bottom pan for convenient cleanout access
- Rod style pan prevents freezing and produces lower friction
- Hydraulic lift with up to 30-degree angle optimizes product delivery height
- Durable powder coat finish for maximum corrosion and abrasion resistance

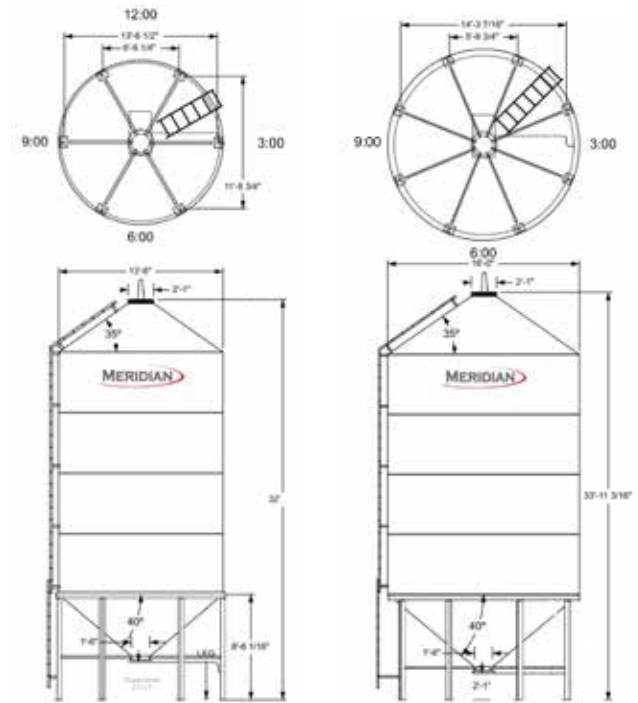

If you would like to learn more about your fertilizer storage choices, your local ADM representative is ready to help.

[ADMadvantage.com/fertilizer](https://www.admadvantage.com/fertilizer)

612-340-5957

Subject to Terms and Conditions in ADM-provided contract. Please see contract for details.