



## Manage Risk Better with Bulk Fertilizer

The cost of crop nutrition is a major piece of your profitability puzzle. One way to take back more control and manage your price risk is to add bulk fertilizer storage capacity to your farm.

ADM is working closely with equipment manufacturer Meridian, a well-known and respected brand. The ADM On-farm Fertilizer Storage Program provides you with one-stop, cost-effective bin and conveyor solutions.

ADM is providing special pricing for program participants. ADM is not a party to the purchase of Meridian storage equipment from Meridian by program participant.



# ADM Fertilizer

On-farm Fertilizer Storage Program:  
Store in Bulk, Save Money

[ADMadvantage.com](http://ADMadvantage.com)

© 2017 Archer Daniels Midland Company | 15170-10/17



*Right by you.*

# ADM On-farm Fertilizer Storage Program

## Competitive Transparent Pricing

ADM provides insight into fertilizer pricing and competitive supply options. We are committed to price transparency on the crop nutrition you need, up to 18 months forward.

## Efficient Logistics

Through ADM's extensive transportation and warehousing network, we deliver the right product at the right time. Having on-farm storage bins means better control over key parts of your operation.

## Quality Supply

ADM is committed to high-quality, diverse fertilizer products that are tailored to your needs, so you can optimize your inputs investment.

## Convenient Financing

Flexible financing options, up to 0%, are available for qualified applicants. Subject to APR through lender partner.

## Peace of Mind

Meridian's premium storage solutions are covered by an extensive manufacturer's warranty:

- 10-year structural warranty on bins
- 5-year powder coating warranty on bins
- 1-year structural and paint warranty on conveyors

## Meridian Multi-purpose Smoothwall Bins Feature:

Model 1420 or 1620

- Capacity of 104 or 150 tons
- Premium powder coat finish for years of corrosion and abrasion resistance
- Cone-shaped design ensures 100% cleanout for zero waste
- Custom-designed venting helps to prevent moisture inside the bin
- Premium, stainless steel, rack-n-pinion slide gate with crank
- Complete sidewall and roof ladder
- 24" clearance under the slide gate
- 15' 6" diameter/1520 multi-purpose bins are applicable for states that cannot ship 1620 bins

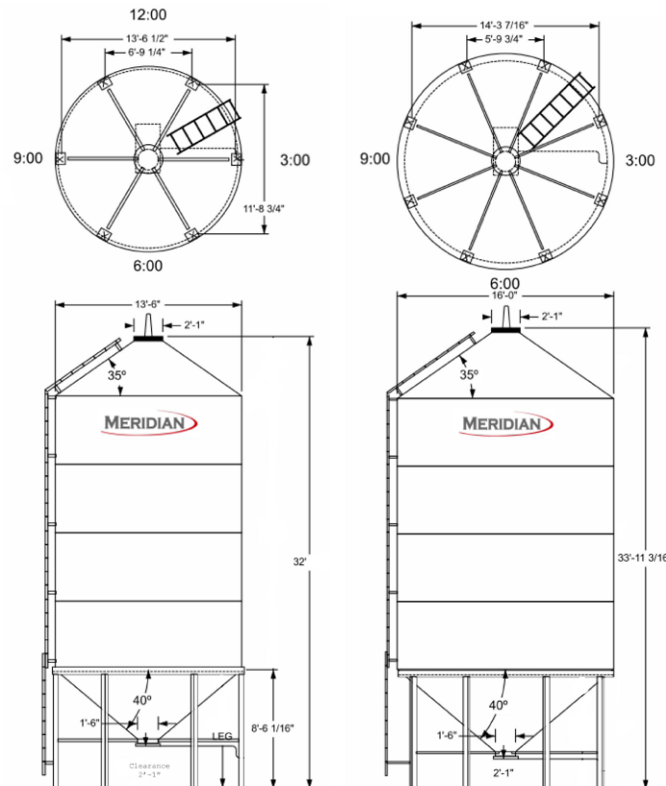

## Meridian Conveyors Feature:

- Reliable and long-lasting design
- High-capacity belt with unique crescent shaped cleats provide superior product movement
  - The rM series belt conveyor features gas or diesel motor or PTO drive
- Available with two drive systems: Single End or Dual End
  - Provides flexibility based on conveyor length and capacity requirements
- Easy-to-remove bottom pan for convenient cleanout access
- Rod style pan prevents freezing and produces lower friction
- Hydraulic lift with up to 30-degree angle optimizes product delivery height
- Durable powder coat finish for maximum corrosion and abrasion resistance

If you have questions or are ready to apply for ADM On-farm Fertilizer Storage, your local ADM representative is ready to help .

[ADMadvantage.com/fertilizer](https://www.admadvantage.com/fertilizer)

1-800-366-6999

Subject to Terms and Conditions in ADM-provided contract. Please see contract for details.